

ROTOR	CFR	CAPACITIES IN CUBIC FEET PER MINUTE						
		5 RPM	10 RPM	15 RPM	20 RPM	25 RPM	30 RPM	35 RPM
6 VANE	.36	1.80	3.60	5.40	7.20	9.00	10.80	12.60
8 VANE	.34	1.70	3.40	5.10	6.80	8.50	10.20	11.90

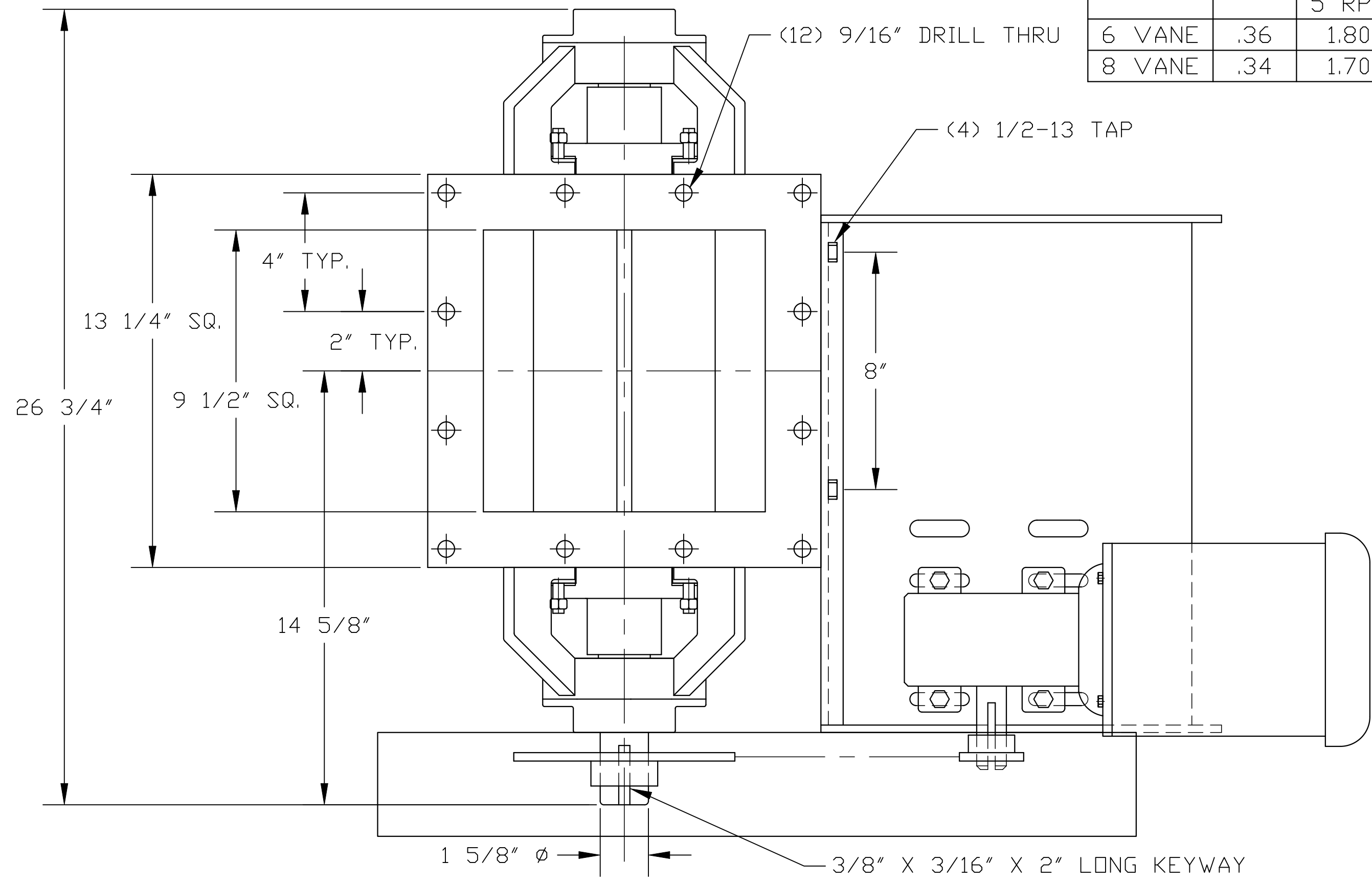

DATA FOR NORMAL SERVICE APPLICATIONS			
MOTOR HP	FEEDER RPM	A	B
1/2 TEFC	7 THRU 9	33 1/2	14 1/2
3/4 TEFC	10 THRU 14	33 1/2	14 1/2
1 TEFC	15 THRU 22	33 1/2	14 1/2
1 1/2 TEFC	23 THRU 35	34	14 1/2
2 TEFC	40 THRU 47	34	14 3/4

DATA FOR SEVERE SERVICE APPLICATIONS			
MOTOR HP	FEEDER RPM	A	B
3/4 TEFC	7 THRU 9	33 1/2	14 3/4
1 TEFC	10 THRU 14	33 1/2	14 3/4
1 1/2 TEFC	15 THRU 22	34	14 3/4
2 TEFC	23 THRU 35	34	14 3/4

NOTES:
 1. ALL MOTORS: 3-60-230/460
 2. INFORMATION IS BASED UPON CATALOG DATA. THIS INFORMATION MUST BE USED IN CONJUNCTION WITH, AND NOT IN SUBSTITUTION FOR, THE APPLICABLE PRODUCT CATALOG WHICH CONTAINS IMPORTANT PRECAUTIONS AND OTHER PERTINENT INFORMATION.

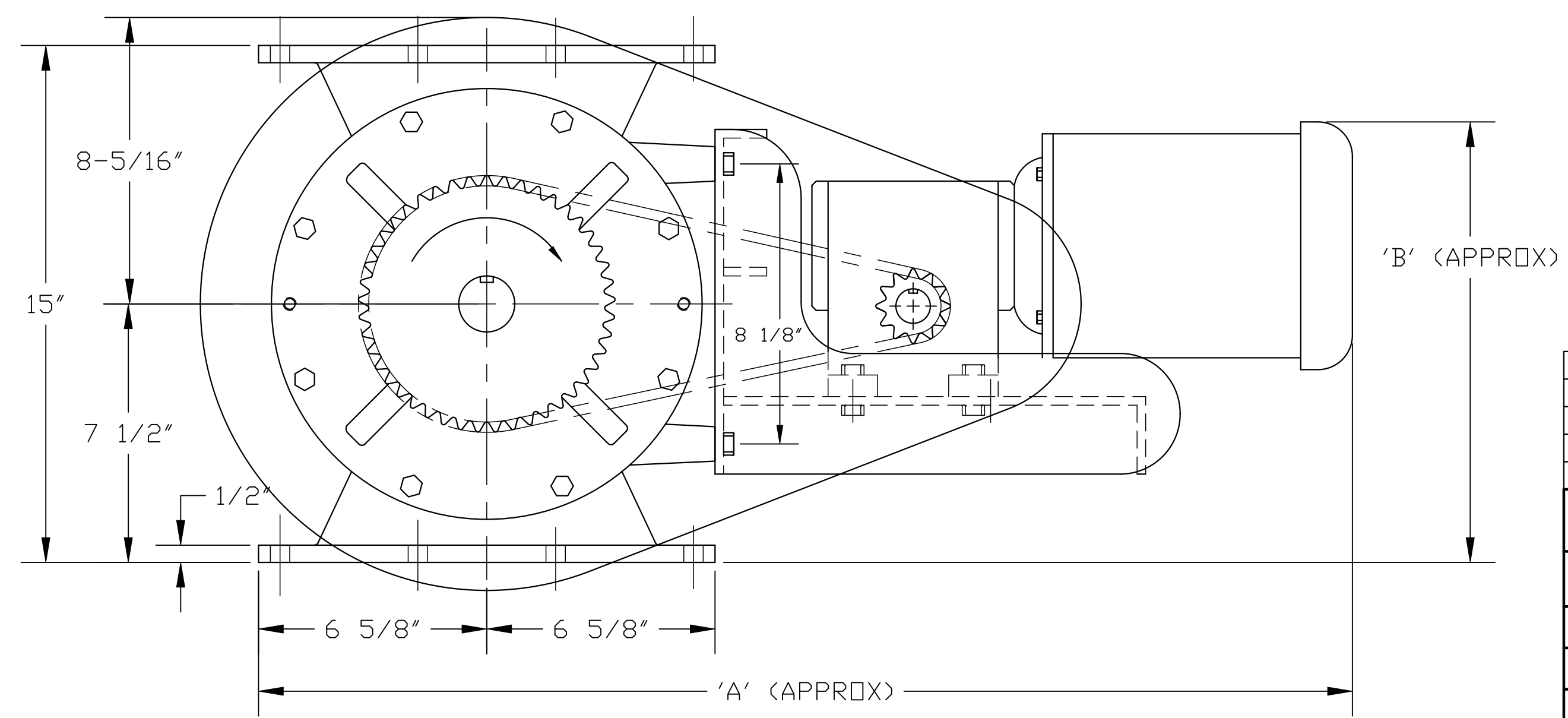

D	8-23-12	REVISED TITLE BLOCK	DRP
C	10-19-04	UPDATED MODEL NAME	SA
B	10-29-96	STD GUARD SHOWN, 8-5/16" DIM ADDED	J.M.
A	10-7-92	REDRAWN ON CAD	TD

REVISIONS

WM. W. MEYER & SONS, INC.
LIBERTYVILLE, ILLINOIS

10 X 10 HDX SQUARE FLANGE FEEDER ASSEMBLY WITH TYPICAL RECOMMENDED GEARMOTORS

OUR S.D. NO.		REF. S.D. NO.	
DRAWN TD	DATE 10-21-88	DRAWING NUMBER	
APPROVED	SCALE 5/16	430D-840	