

ROTOR	CFR	CAPACITIES IN CUBIC FEET PER MINUTE					
		5 RPM	10 RPM	15 RPM	20 RPM	25 RPM	30 RPM
6 VANE	.64	3.20	6.40	9.60	12.80	16.00	19.20
8 VANE	.61	3.05	6.10	9.15	12.20	15.25	18.30

DATA FOR NORMAL SERVICE APPLICATIONS			
MOTOR HP	FEEDER RPM	A	B
3/4 TEFC	7 THRU 9	37 1/8	15 1/8
1 TEFC	10 THRU 14	37 1/8	15 1/8
1 1/2 TEFC	15 THRU 22	37 3/4	15 1/8
2 TEFC	23 THRU 35	37 3/4	15 1/8

DATA FOR SEVERE SERVICE APPLICATIONS			
MOTOR HP	FEEDER RPM	A	B
1 TEFC	7 THRU 9	38 3/8	16
1 1/2 TEFC	10 THRU 14	38 5/8	16
2 TEFC	15 THRU 22	38 5/8	16
3 TEFC	23 THRU 35	42 3/4	17 1/4

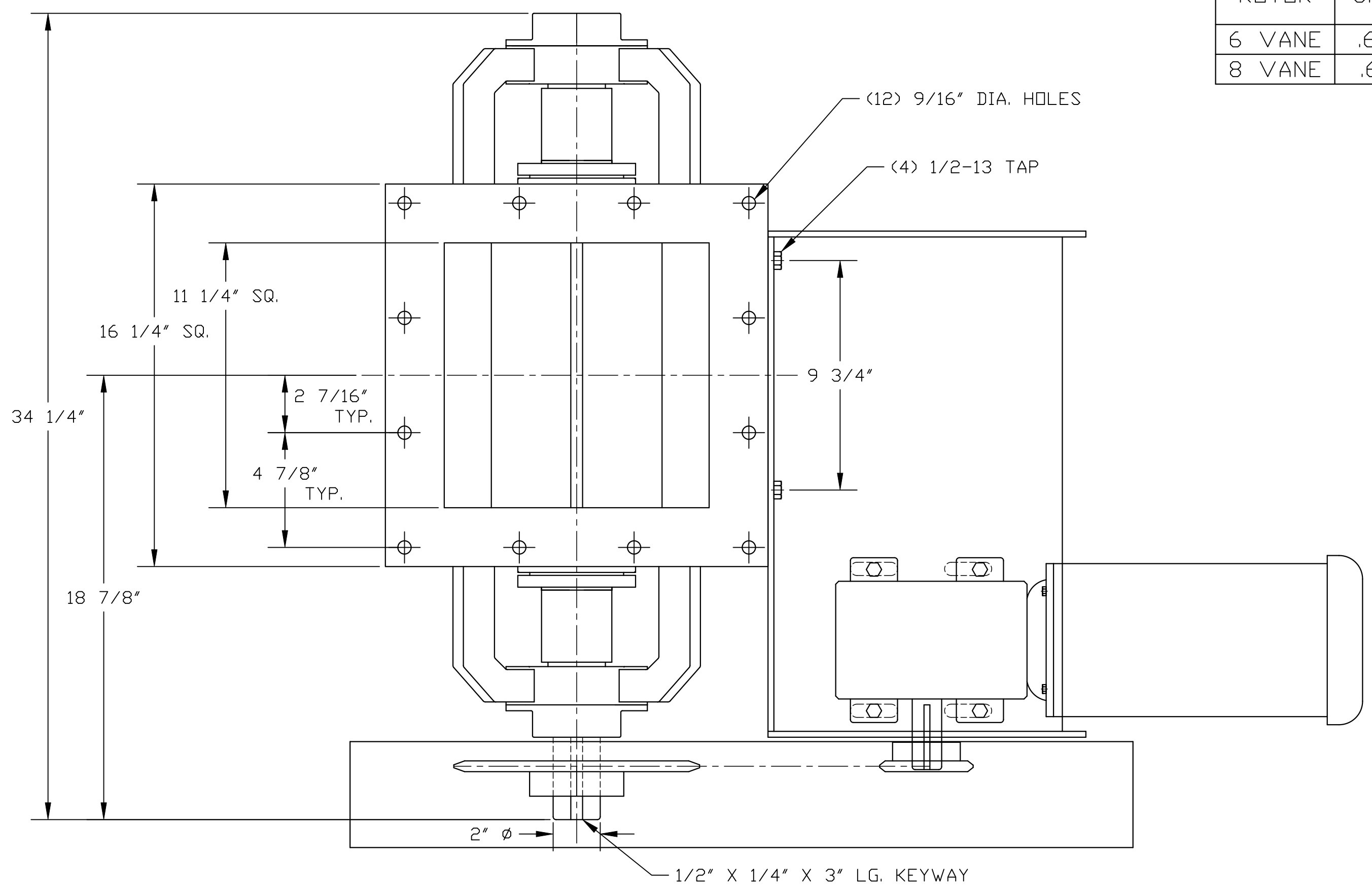

NOTES:  
 1. ALL MOTORS: 3-60-230/460  
 2. INFORMATION IS BASED UPON CATALOG DATA. THIS INFORMATION MUST BE USED IN CONJUNCTION WITH, AND NOT IN SUBSTITUTION FOR, THE APPLICABLE PRODUCT CATALOG WHICH CONTAINS IMPORTANT PRECAUTIONS AND OTHER PERTINENT INFORMATION.

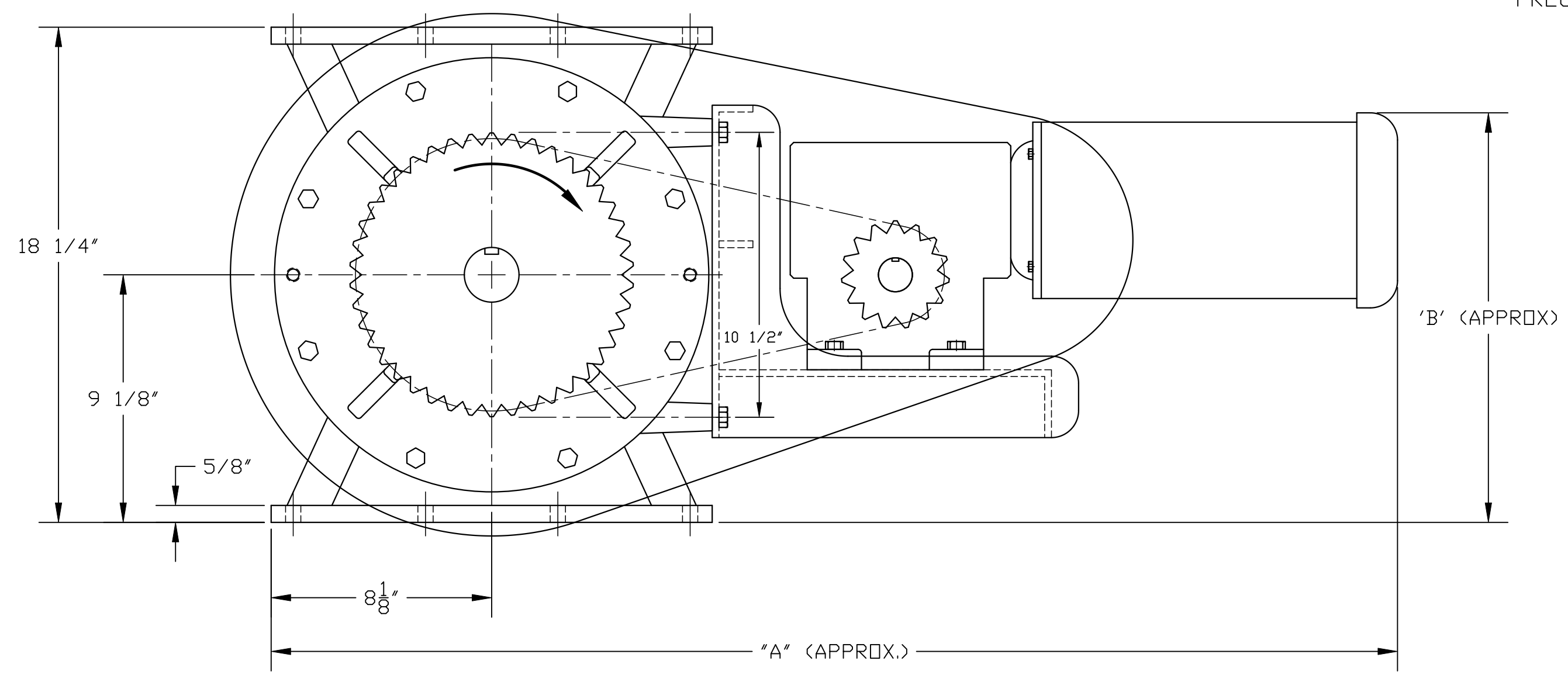

REVISIONS			
C	3-5-14	REVISED TITLE BLOCK	DRP
B	10-19-04	UPDATED MODEL NAME	SA
A	9-30-92	REDRAWN ON CAD	TD
<b>WM. W. MEYER &amp; SONS, INC.</b> LIBERTYVILLE, ILLINOIS			
12 X 12 HDX SQUARE FLANGE FEEDER ASSEMBLY WITH TYPICAL RECOMMENDED GEARMOTORS			
OUR S.D. NO.		REF. S.D. NO.	
DRAWN TD	DATE 10-21-88	DRAWING NUMBER	
APPROVED	SCALE 1/4	430E-761	